

AFD for NBC

This application note is an addendum to the NBC document "NBC DTV Transition Technical Guidelines."



Overview

This is an application note for Harris products that provide AFD (Active Format Description) functionality. Included in the application note are the following products:

- 1) NetVX™ and FlexiCoder® MPEG encoders
- 2) The XHD6801+ and XHD-3903 modular up-, down- and cross-converters with AFD capability for real-time, frame-accurate aspect ratio conversions (ARC)
- 3) The X75™ all-in-one processor, for use in applications that do not require frame-accurate ARC
- 4) The X85™ advanced all-in-one processor for real-time, frame-accurate aspect ratio conversions (available in February 2009)

It is assumed the AFD device is already setup for the appropriate conversion and/or processing tasks and that the parameters for the ARC processing by AFD are required to be set.

Note regarding FlexiCoder®:

Release 4.1.10 on the Harris Premier Web site adds AFD support on the HDP-100 high-definition (HD) encoder card based on AFD packets received on VANC (Vertical Ancillary Data) in the HD-SDI input to the HDP-100. AFD packets are also inserted in standard-definition (SD) bitstreams generated by the EVA-152, EVA-160, EVA-162, EVA-200 and EVA-210 SD encoder modules. See the Product Release Description (PRD) in the release bundle for additional details on how to use this new feature.

Customers who have upgraded to the NetVX platform as their primary encoding system and still use a FlexiCoder® as a redundant encoder will receive standard remote installation and upgrade assistance at no charge.

The firmware installation will affect service: Depending on the board population, an outage of up to 10 minutes may be experienced.

If the firmware does not perform to the customer's expectations, Harris Customer Service will remotely assist in returning the FlexiCoder encoder to the previous firmware revision.

Please note that although this release is being provided for the FlexiCoder encoder, it remains a discontinued product. Installing or using this release does not create any new warranty on the FlexiCoder hardware or software.



It is highly recommended that the product be verified to be running the latest code:

XHD6801+

To determine the code version:

Other > Firmware Version:

To obtain the latest code:

<https://premier.harris.com/broadcast/downloads.asp?cat=1596>

XHD-3903

To determine the code version:

Other > Firmware Version:

To obtain the latest code:

<https://premier.harris.com/broadcast/downloads.asp?cat=1029>

X75™

To determine the code version:

System Config > Status/Version Info > SW Ver

To obtain the latest code:

<https://premier.harris.com/broadcast/downloads.asp?cat=1423>

Application #1:

Recommendations for SD-Only Stations

For stations that do not broadcast any locally generated HD content, AFD insertion methods can be fairly straightforward. As shown in Table 1, an AFD code of "1001" should be inserted in all up-converted SD-originated content.

The diagram below illustrates how a simple AFD insertion device can be installed within an existing HD signal path down-stream of the primary up-converter device.

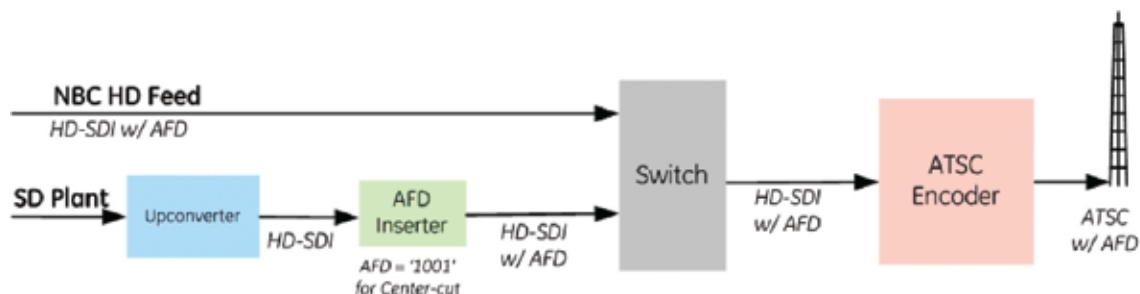

Figure 1: Local AFD Insertion after Up-conversion

XHD6801+

Video > Output > Embedder > Active Format Description (AFD)
Select> 4:3 Full (AFD code: 1001)
Video > Processing > ARC > ARC Preset Up/Down/Cross/SD-ARC
> AFD-ALTR

XHD-3903

Video > Output > Embedder > Active Format Description (AFD)
Select> 4:3 Full (AFD code: 1001)
Video > Processing > ARC > ARC Preset Up/Down/Cross/SD-ARC
> AFD-ALTR

X75™

Video Setup > Digital Output > HD Out (or SDI 1 Out, or SDI 2 Out)
> HD/SD1/SD2 Out > AFD Insert > CUSTOM

Video Setup > Digital Output > HD Out (or SDI 1 Out, or SDI 2 Out)
> HD/SD1/SD2 Out > AFD Select > 4:3 p (AFD code: 1001)
Video Setup > Processing > ARC (SD or HD Out) > SD or HD AEC Auto
Adjust > AFD ALTR)

NetVX™/FlexiCoder®

In the case where the ATSC encoder is a Harris® NetVX™ or FlexiCoder®, the encoder itself is able to automatically insert AFD information into the ATSC bitstream. When enabled, this feature will use the AFD from the incoming HD-SDI video; if no AFD is present, a default AFD value will be transmitted. On NetVX™, this default value is set through the Videm EMS, **Encoder_Properties -> Video -> Video_Picture -> AFD_Default** drop-down box. On FlexiCoder®, the default AFD is set using the craft port, and instructions are included with the release notes for FlexiCoder release 4.1.10.

Application #2:

Alternatively, many up-converter devices will automatically insert a programmable AFD code into the HD-SDI signal output as shown below.

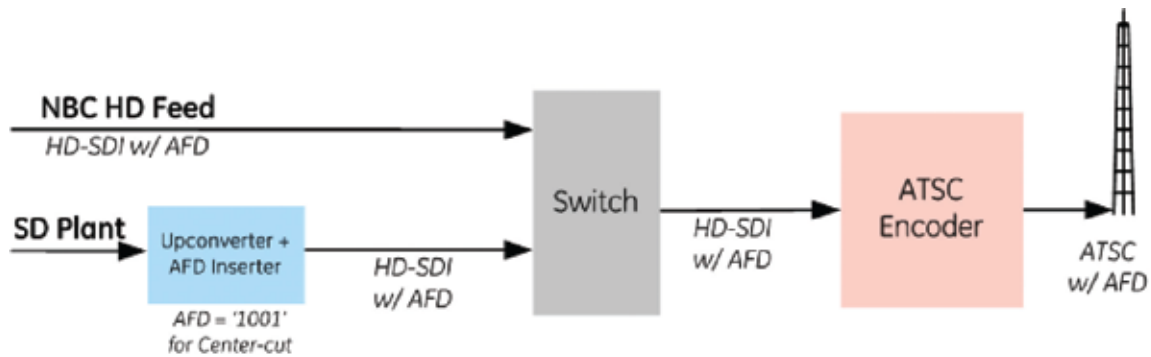

Figure 2: Local AFD Insertion within Up-converter

XHD6801+

Video > Input > SD1 Input Std Select > 525
Video > Output > Output Video Std Select > choose your format
Video > Output > Embedder > AFD Control > CUSTOM
Video > Output > Embedder > Active Format Description (AFD) Select
> 4:3 Full (AFD code: 1001)

XHD-3903

Video > Input > SD1 Input Std Select > 525
Video > Output > Output Video Std Select > choose your format
Video > Output > Embedder > AFD Control > CUSTOM
Video > Output > Embedder > Active Format Description (AFD) Select
> 4:3 Full (AFD code: 1001)

X75™

Video Setup > Digital Output > HD Out (or SDI 1 Out, or SDI 2 Out) >
HD/SD1/SD2 Out > AFD Insert > CUSTOM
Video Setup > Digital Output > HD Out (or SDI 1 Out, or SDI 2 Out) >
HD/SD1/SD2 Out > AFD Select > 4:3 p (AFD code: 1001)

NetVX™/FlexiCoder®

In the case where the ATSC encoder is a Harris NetVX™ or FlexiCoder®, the encoder itself is able to automatically insert AFD information into the ATSC bitstream. When enabled, this feature will use the AFD from the incoming HD-SDI video; if no AFD is present, a default AFD value will be transmitted. On NetVX™, this default value is set through the Videm EMS, **Encoder_Properties -> Video -> Video_Picture -> AFD_Default** drop-down box. On FlexiCoder®, the default AFD is set using the craft port, and instructions are included with the release notes for FlexiCoder release 4.1.10.

Application #3:

Recommendations for HD Stations

For stations that air local HD programming (HD newscasts, syndicated programming, etc.), AFD insertion methods may be more complex. However, as most locally aired HD programming would likely be meant for delivery in full-screen for SD viewers, inserting a fixed AFD code to signal down-conversion devices to center-cut is suggested as shown below.

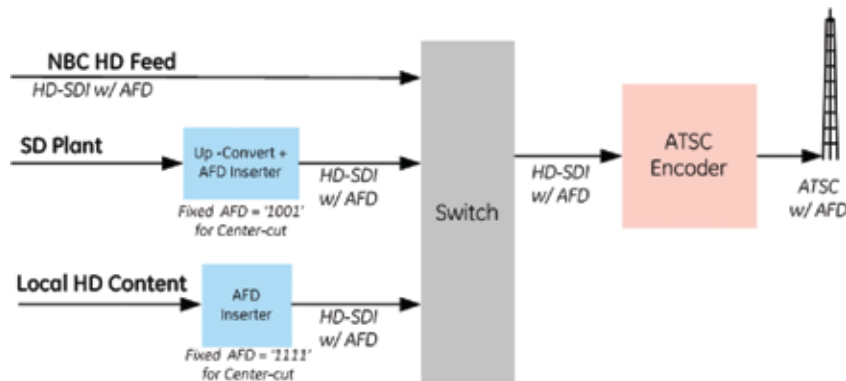

Figure 3: Local AFD Insertion within Up-converter

XHD6801+ as up-converter & AFD inserter

Video > Input > SD1 Input Std Select > 525
Video > Output > Output Video Std Select > choose your format
Video > Output > Embedder > AFD Control > CUSTOM
Video > Output > Embedder > Active Format Description (AFD) Select > 4:3 Full (AFD code: 1001)
Video > Processing > ARC > ARC Preset Up > AFD (ALTR)

XHD-3903 as up-converter & AFD inserter

Video > Input > SD1 Input Std Select > 525
Video > Output > Output Video Std Select > choose your format
Video > Output > Embedder > AFD Control > CUSTOM
Video > Output > Embedder > Active Format Description (AFD) Select > 4:3 Full (AFD code: 1001)
Video > Processing > ARC > ARC Preset Up > AFD (ALTR)

XHD6801+ as inserter

Video > Output > Embedder > Active Format Description (AFD) Select > 16:9 A 4:3 (AFD code: 1111)

XHD-3903 as inserter

Video > Output > Embedder > Active Format Description (AFD) Select > 16:9 A 4:3 (AFD code: 1111)

X75™ as up-converter and AFD inserter

Video Setup > Routing Setup > All output Select > choose input
Video Setup > Digital Output > HD OUT > HD standard select > choose format

Video Setup > Digital Output > HD Out (or SDI 1 Out, or SDI 2 Out) > HD/SD1/SD2 Out > AFD Insert > CUSTOM

Video Setup > Digital Output > HD Out (or SDI 1 Out, or SDI 2 Out) > HD/SD1/SD2 Out > AFD Select > 4:3 p (AFD code: 1001)

Video Setup > Processing > ARC (SD or HD Out) > SD or HD AEC Auto Adjust > AFD ALTR)

X75™ as AFD inserter

Video Setup > Digital Output > HD Out (or SDI 1 Out, or SDI 2 Out) > HD/SD1/SD2 Out > AFD Insert > CUSTOM

Video Setup > Digital Output > HD Out (or SDI 1 Out, or SDI 2 Out) > HD/SD1/SD2 Out > AFD Select > 16:9 A 4:3 (AFD code: 1111)

Video Setup > Processing > ARC (SD or HD Out) > SD or HD AEC Auto Adjust > AFD ALTR)

NetVX™/FlexiCoder®

In the case where the ATSC encoder is a Harris NetVX™ or FlexiCoder®, the encoder itself is able to automatically insert AFD information into the ATSC bitstream. When enabled, this feature will use the AFD from the incoming HD-SDI video; if no AFD is present, a default AFD value will be transmitted. On NetVX™, this default value is set through the Videm EMS, **Encoder_Properties -> Video -> Video_Picture -> AFD_Default** drop-down box. On FlexiCoder®, the default AFD is set using the craft port, and instructions are included with the release notes for FlexiCoder release 4.1.10.

Application #4:

Simplified Local AFD Insertion

One option for stations is to install an AFD inserter with an auto-insert function. The "auto" function will pass any AFD codes from the HD-SDI input to the output. In the absence of AFD on the HD-SDI input, a default value will be frame-accurately inserted into the HD-SDI output. Using such a device, the following simplified scenario can be implemented.

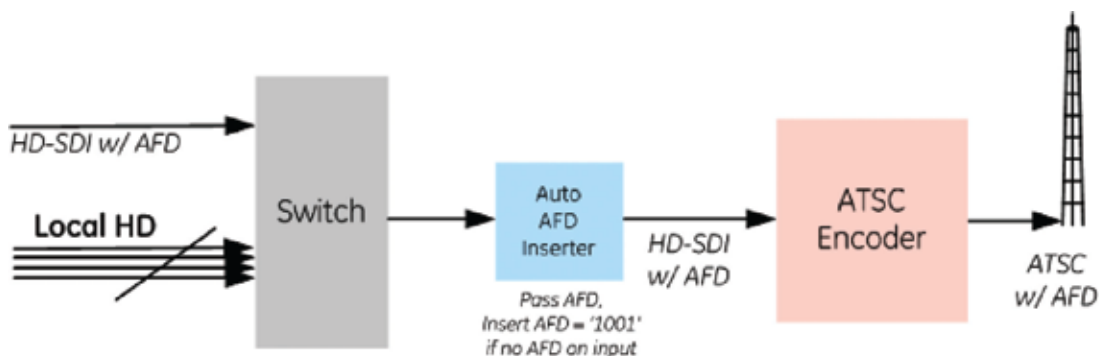

Figure 4: Simplified "Auto" AFD Insertion model

The auto mode is present on XHD-3903 and XHD6801+ as below;
 For XHD6801+: Video > Processing > ARC > Auto ARC Reset . NO.
 For XHD-3903: Video > Processing Aspect Ratio > Conversion (ARC)
 > Auto ARC Reset . NO.
 In the case where the ATSC encoder is a Harris NetVX™ or FlexiCoder®,
 the automatic AFD insertion function is built into the encoder. When

enabled, this feature will use the AFD from the incoming HD-SDI video;
 if no AFD is present in the video, a default AFD value will be transmitted.
 On NetVX™, this default value is set through the Vidiem EMS,
Encoder_Properties -> Video -> Video_Picture -> AFD_Default
 drop-down box. On FlexiCoder®, the default AFD is set using the craft port,
 and instructions are included with the release notes for FlexiCoder release 4.1.10.

Application #5:

Local Down-conversion

Stations are encouraged to maintain/install direct fiber connection of HD/SD signals to cable, satellite and telco providers when feasible. In these cases, down-conversion of the station's primary HD signal can be implemented as shown below.

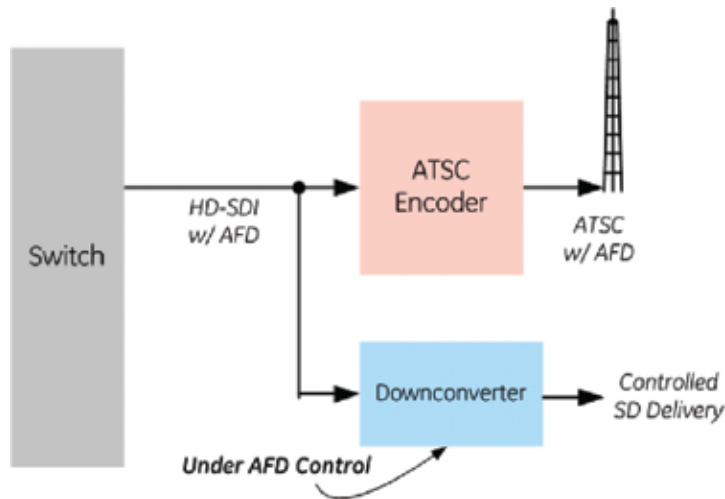

Figure 5: AFD Controlled Down-conversion

XHD-3903 & XHD-6801+:

Please follow basic setup to select Input as HD and Output as SDI.
 Video > Processing > ARC > ARC Preset Down > AFD (ALTR)

Written by:

Prashant Patel, Customer Service (1-888-54-8246 x2637, email prashant.patel@harris.com)
 Randy Conrod, Product Manager (1-416-443-2741, email randy.conrod@harris.com)
 John Mailhot, General Manager, Video Networking (1-908-927-1201, email john.mailhot@harris.com)
 Clarence Hau and Christopher Perretta of NBC

For more information, please visit www.broadcast.harris.com.

Harris is a registered trademark of Harris Corporation. Trademarks and tradenames are the property of their respective companies.