

Selenio™ Media Convergence Platform

Ingest Application

Business Challenge

Today's systems are faced with a multitude of video and audio formats (as well as data and metadata) as remote signals are received. Frame synchronization is necessary throughout the entire system workflow to sync and time the video and audio. Signals might come into a facility (e.g., a studio) from an external source (such as a network operations center). Alternatively, signals might move from room-to-room within a single building and require retiming along the way.

Remote signals can arrive on fiber (uncompressed or compressed) over many types of links, including satellite and IP networks. Signals might require conversion from optical to electrical, demultiplexing from a transport stream, and MPEG decoding before being synchronized (locked to house sync generator) and lip sync adjusted. If the signal is unknown, video can require conversion to the native format or formats. As well, AFD metadata (for aspect ratio conversion) might need to be inserted, closed captioning might require transcoding, audio might require decoding or re-mapping, and audio metadata might require verification or updating. Video and audio might require adjustment for incorrect levels, automatic legalization or loudness correction.

With an increasing number of formats for video (SD, HD, 1080p, 3D, etc.) and audio (2.0, 5.1, 7.1), a single point of control before ingest is key. Once the content is processed as required, it can be ingested into the server system or passed into master control, depending on the nature of the content. For example, an affiliate might receive a commercial feed at 3:00 a.m. This particular feed would likely be frame synchronized into the server system for playback later in the day. Alternatively, when the same affiliate received a national news feed, it would likely bypass the server and be sent directly to master control and then played to air live.

Solution

The Selenio™ platform takes a layered approach to handling any ingest application, from the very simple to the complex, and Selenio modules can readily adapt to any signal coming into the facility. From frame synchronization with fiber options (one layer) and processing, to conversion (another layer) with advanced audio processing (another layer) and MPEG video decoding (another layer), Selenio processing modules enable multiple levels of functionality to be added on to the frame sync function at the same point in the system. This layered approach delivers unparalleled flexibility.

Selenio Media Convergence Platform

Application: Ingest

- Synchronize and process remote video and audio for the native format of the end user's system.



SELENIO[™]
MEDIA CONVERGENCE PLATFORM

Generic Example

The user selects whether the signal has been received on coaxial cable or optical fiber, or has been demultiplexed and decoded. As needed, Selenio performs frame synchronization (as well as color correction, legalization, embedded audio processing and logo insertion), along with conversion and frame rate conversion. Unbalanced and balanced audio interfaces, as well as analog audio interfaces, can be added via audio expansion modules. Advanced audio processing can also be added, including Dolby® E and Dolby® Digital encoding and decoding, DTS Neural Surround™ Up/DownMix and MultiMerge, and DTS Neural Loudness Control. (See typical ingest applications illustrated on pages 3-7.)

Business Value

No matter what type of signal comes into the facility – and whether the end user knows the signal format in advance or not – the highly adaptable Selenio frame can handle it. Through a single platform, Selenio can perform MPEG and baseband processing with advanced audio processing. Users realize significant space and power savings.

Since purpose-built flexibility for ingest applications is inherent in the Selenio platform, users benefit from:

- A user-customized, layered approach — The highly flexible Selenio platform offers single- and dual-channel frame synchronization, with all of the video and audio processing that is required for ingest applications.
- Greater density — Through the use of new HD-BNC connectors, which offer the same strength and are the same bayonet-locking connectors as standard BNC connectors, Selenio delivers increased density.
- Cost-effective design — Video and audio signals are connected internally within the frame, resulting in fewer external cables (and avoidance of the associated costs of cable connection).
- Space-saving architecture — New channels can be added without taking up valuable real estate, as decoders and converters coexist within the same frame, under the same control.
- Easier control — Through an intuitive, Web-based GUI that utilizes functional block diagrams, operators can confidently configure, monitor and manage the platform's vast, advanced functionality.
- Less downtime through redundancy capabilities — Options for redundancy include a second power supply, a second controller and a local control panel. N+1 redundancy is supported via an external router or a crosspoint on the controller module.

Making a Difference

The Selenio platform is unmatched in the industry with respect to density scale and flexibility for full-featured multichannel video and audio processing, distribution and compression.

Only Selenio offers:

- Superior flexibility for ingest applications — dual-channel version, frame rate conversion option, MPEG demultiplexing and decoding easily added
- Baseband processing and networking compression combined within a single platform
- Internal connectivity of modules over bidirectional high-speed busses
- Built-in processing such as color correction, legalization and logo insertion
- Virtually any advanced audio capability — including Dolby® codecs, MPEG audio codecs, AAC codecs and DTS Neural Surround™ Up/DownMix and DTS Neural Loudness Control — easily added.

Summary

In a typical ingest application, the Selenio media convergence platform can provide significant cost benefits over competitive solutions. In an analysis of the Selenio platform's performance against a major competitor, it was estimated that over a five-year period, users can benefit from up to 29 percent savings.

Systems today must handle a large number of video and audio formats (as well as data and metadata) as signals enter the facility. The Selenio platform can manage any ingest application, from simple frame synchronization to more complex, layered functions (up to four layers of functionality can be added on to the frame sync function at the same point in the system). This layered approach delivers unparalleled flexibility for customers. For full-featured multichannel video and audio processing, distribution and compression, the Selenio platform's cost- and space-effective design features (video and audio connected internally, decoders and converters within the same frame, etc.), increased density (through the use of HD-BNC connectors) and ease of control (through an intuitive web-based GUI) are unmatched in the industry.

Ingest Application: Example 1 Dual-Channel (Frame Sync and/or Upconversion)

Legacy Analog, SDI/AES Input
SDI/AES Output

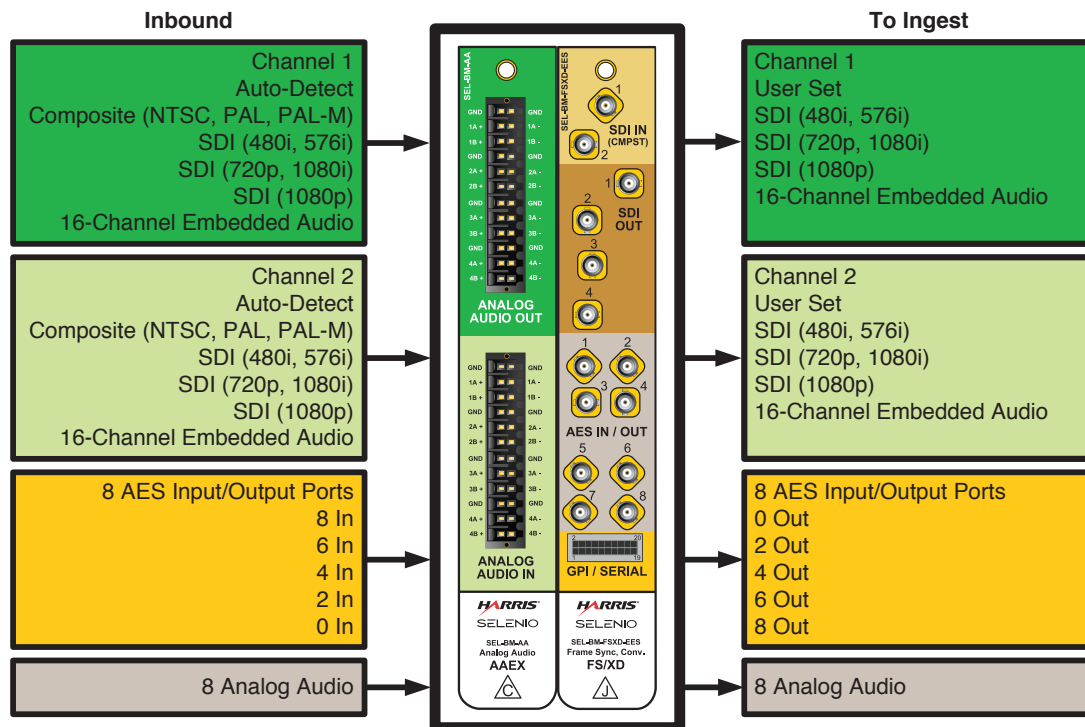

SEL-2XD1-EES

Dual-channel video conversion front module with up, down, cross, frame rate and aspect ratio conversion, logo generator/inserter, and full embedded audio processing, includes single back module with HD-BNC connectors for SDI and composite input, SDI outputs, 8 AES (unbalanced) input/output ports and socket/plug for 4 GPI inputs, 4 GPI outputs and two serial data connections

SELOPT-AAEX1-AABS

Analog audio expansion front module, adds more inputs and outputs to FS/XD, includes single back module with two Weidmuller connectors for 8 analog (balanced) inputs and 8 analog (balanced) outputs, mating connectors (2) included

Adding Advanced Audio Options

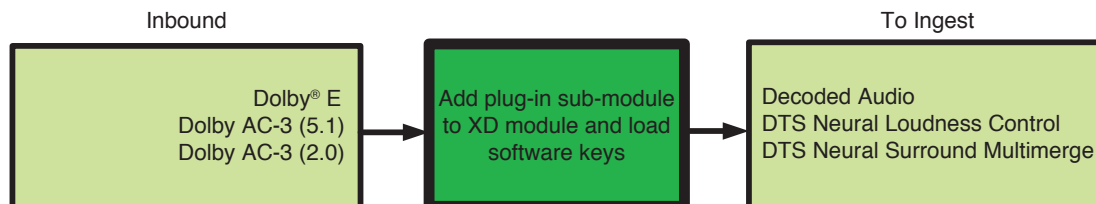

SELOPT-ADVAUD (Quantity: 1)

APM (Audio Processing Module) plug-in advanced audio processing for FS, XD, DAEX, DAEX-B, AAEX (requires software key license option(s))

SELOPT-SK-DED (Quantity: 2)

Software Key License for one Dolby® E Decoder (for FS, XD, DAES, AAES)

SELOPT-SK-DDD (Quantity: 2)

Software Key License for Dolby® Digital Pro Decoder (5.1 or 2.0) (for FS, XD, DAES, AAES)

SELOPT-SK-DTS (Quantity: 16)

Software Key License for DTS Neural Technologies (3 required for Upmix or Downmix or 5.1 Loudness Control, 4 required for Multimerge, 1 required for 2.0 Loudness Control)

Ingest Application: Example 1A

Single-Input Channel with Dual-Processed Outputs

Legacy Analog, SDI/AES Input
SDI/AES Output

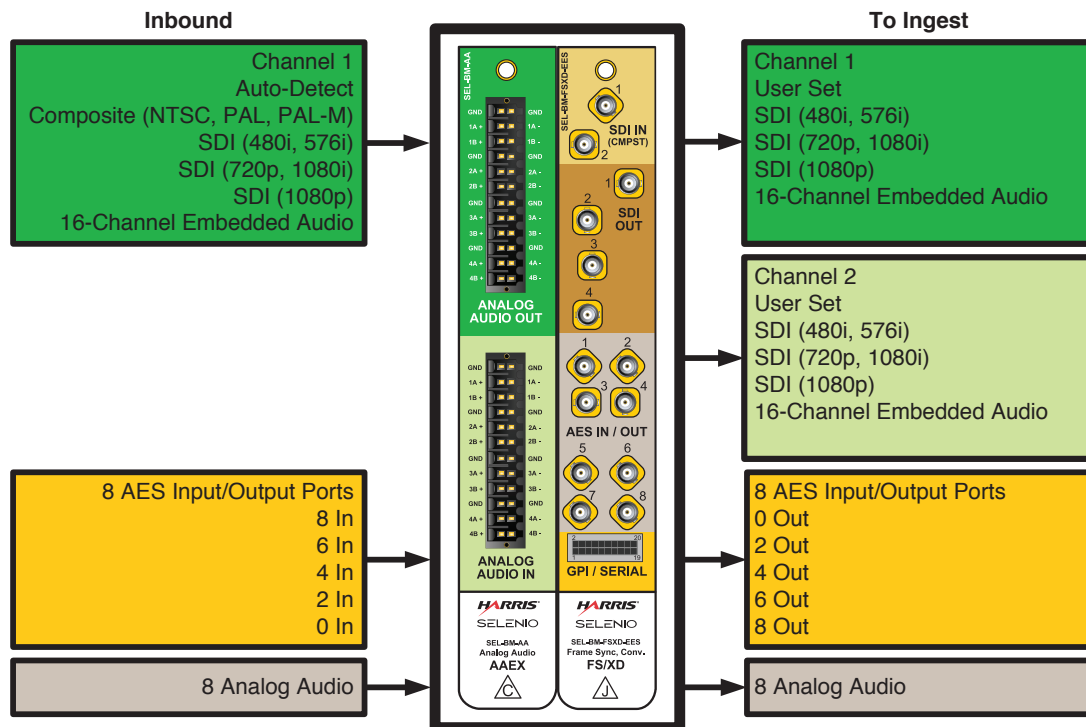

SEL-2XD1-EES

Dual-channel video conversion front module with up, down, cross, frame rate and aspect ratio conversion, logo generator/insertion, and full embedded audio processing, includes single back module with HD-BNC connectors for SDI and composite input, SDI outputs, 8 AES (unbalanced) input/output ports and socket/plug for 4 GPI inputs, 4 GPI outputs and two serial data connections

SELOPT-AAEX1-AABS

Analog audio expansion front module, adds more inputs and outputs to FS/ XD, includes single back module with two Weidmuller connectors for 8 analog (balanced) inputs and 8 analog (balanced) outputs, mating connectors (2) included

Adding Advanced Audio Options

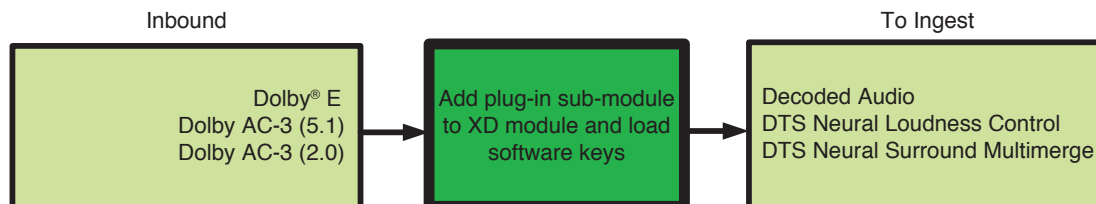

SELOPT-ADVAUD (Quantity: 1)

APM (Audio Processing Module) plug-in advanced audio processing for FS, XD, DAEX, DAEX-B, AAEX (requires software key license option(s))

SELOPT-SK-DED (Quantity: 1)

Software Key License for one Dolby® E Decoder (for FS, XD, DAES, AAES)

SELOPT-SK-DDD (Quantity: 1)

Software Key License for Dolby® Digital Pro Decoder (5.1 or 2.0) (for FS, XD, DAES, AAES)

SELOPT-SK-DTS (Quantity: 8)

Software Key License for DTS Neural Technologies (3 required for Upmix or Downmix or 5.1 Loudness Control, 4 required for Multimerge, 1 required for 2.0 Loudness Control)

Ingest Application: Example 2 Dual-Channel (Frame Sync and/or Upconversion)

Optical Fiber SDI/AES Input
SDI/AES Output

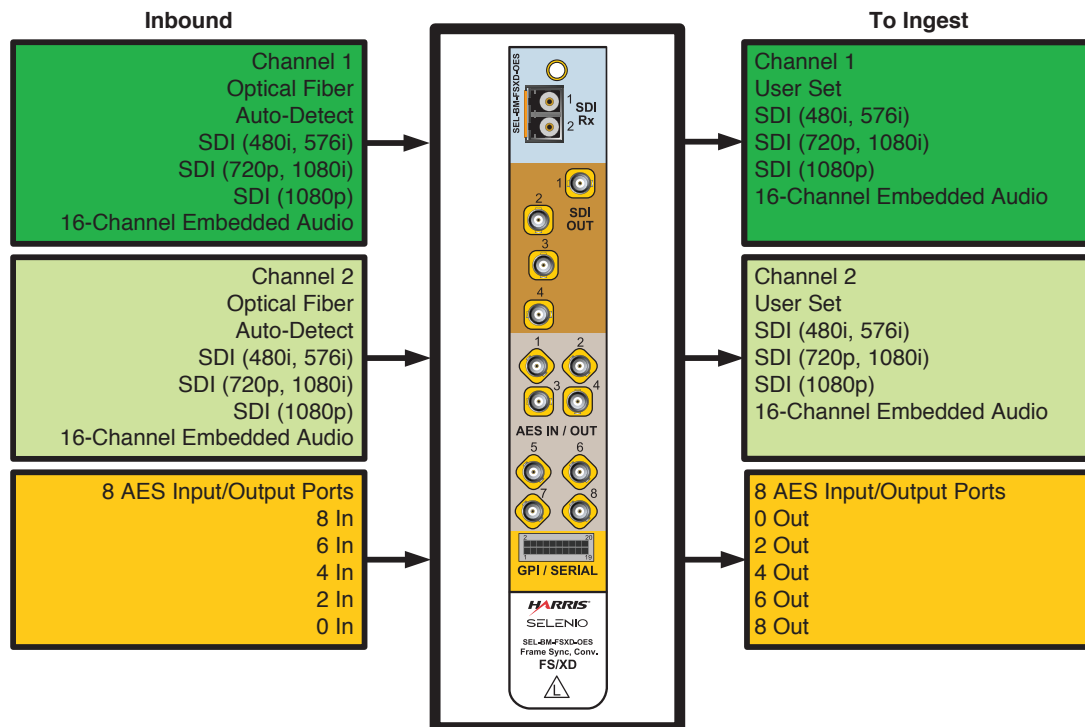

SEL-2XD1-OES

Dual-channel video conversion front module with up, down, cross, frame rate and aspect ratio conversion, logo generator/inserter, 3DTV capability and full embedded audio processing, includes single back module with SFP optical input (order one SFP dual input option separately) for SDI input, HD-BNC connectors for SDI outputs, 8 AES (unbalanced) input/output ports and socket/plug for 4 GPI inputs, 4 GPI outputs and two serial data connections

OP+SFP+RR

Small Form Factor (SFP) for Harris fiber optic products. Dual PIN receiver with pathological support for baseband video

Adding Advanced Audio Options

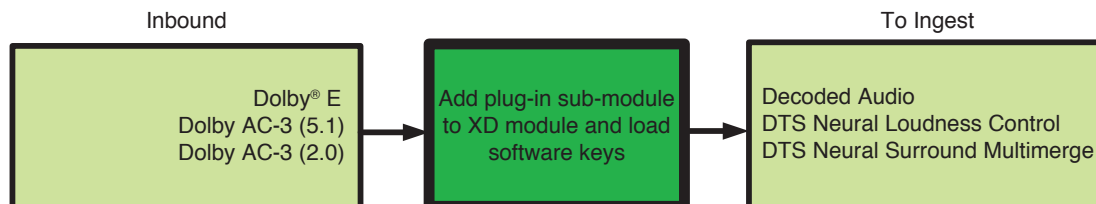

SELOPT-ADVAUD (Quantity: 1)

APM (Audio Processing Module) plug-in advanced audio processing for FS, XD, DAEX, DAEX-B, AAEX (requires software key license option(s))

SELOPT-SK-DED (Quantity: 2)

Software Key License for one Dolby® E Decoder (for FS, XD, DAES, AAES)

SELOPT-SK-DDD (Quantity: 2)

Software Key License for Dolby® Digital Pro Decoder (5.1 or 2.0) (for FS, XD, DAES, AAES)

SELOPT-SK-DTS (Quantity: 16)

Software Key License for DTS Neural Technologies (3 required for Upmix or Downmix or 5.1 Loudness Control, 4 required for Multimerge, 1 required for 2.0 Loudness Control)

Ingest Application: Example 2A

Single-Input Channel with Dual-Processed Outputs

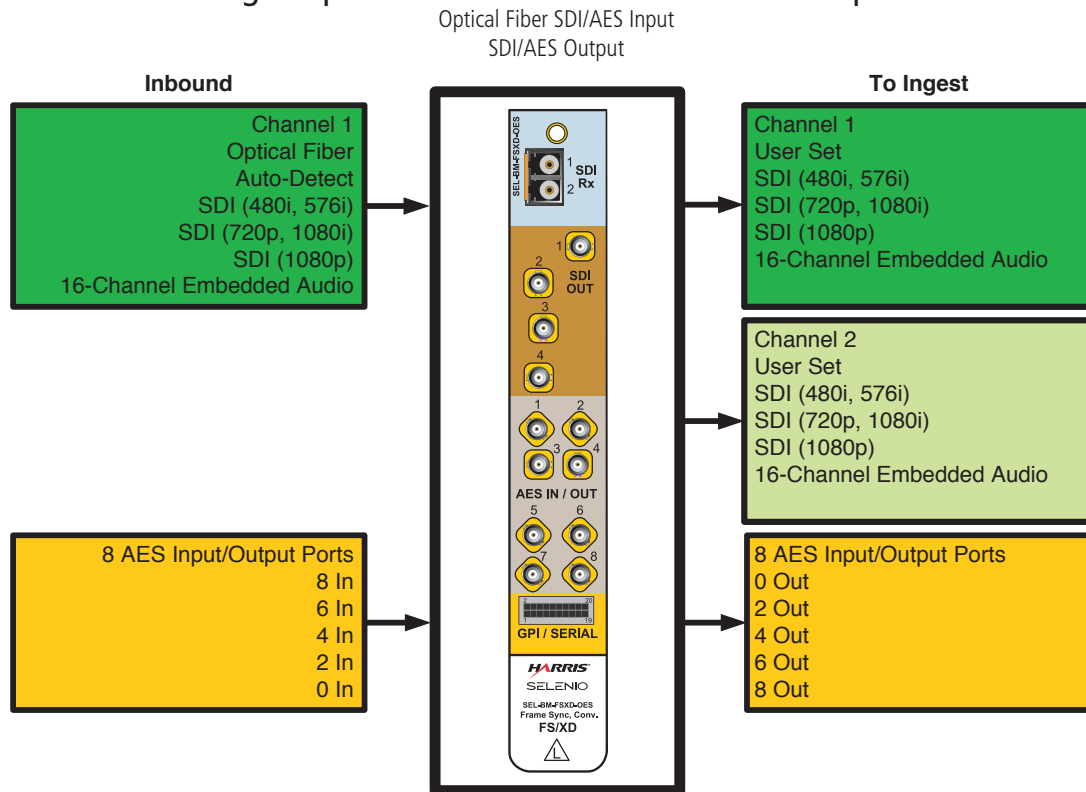

SEL-2XD1-OES

Dual-channel video conversion front module with up, down, cross, frame rate and aspect ratio conversion, logo generator/inserter, 3DTV capability and full embedded audio processing, includes single back module with SFP optical input (order one SFP dual input option separately) for SDI input, HD-BNC connectors for SDI outputs, 8 AES (unbalanced) input/output ports and socket/plug for 4 GPI inputs, 4 GPI outputs and two serial data connections

OP+SFP+RR

Small Form Factor (SFP) for Harris fiber optic products. Dual PIN receiver with pathological support for baseband video

Adding Advanced Audio Options

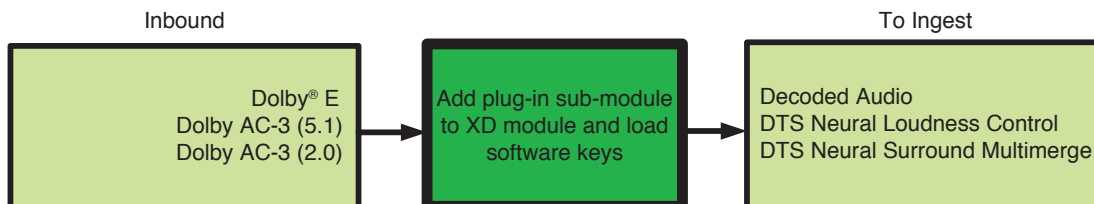

SELOPT-ADVAUD (Quantity: 1)

APM (Audio Processing Module) plug-in advanced audio processing for FS, XD, DAEX, DAEX-B, AAEX (requires software key license option(s))

SELOPT-SK-DED (Quantity: 1)

Software Key License for one Dolby® E Decoder (for FS, XD, DAES, AAES)

SELOPT-SK-DDD (Quantity: 1)

Software Key License for Dolby® Digital Pro Decoder (5.1 or 2.0) (for FS, XD, DAES, AAES)

SELOPT-SK-DTS (Quantity: 8)

Software Key License for DTS Neural Technologies (3 required for Upmix or Downmix or 5.1 Loudness Control, 4 required for Multimerge, 1 required for 2.0 Loudness Control)

Ingest Application: Example 3

Single-Input Channel with Dual-Processed Outputs

ASI or IP Compressed Input
SDI/AES Output

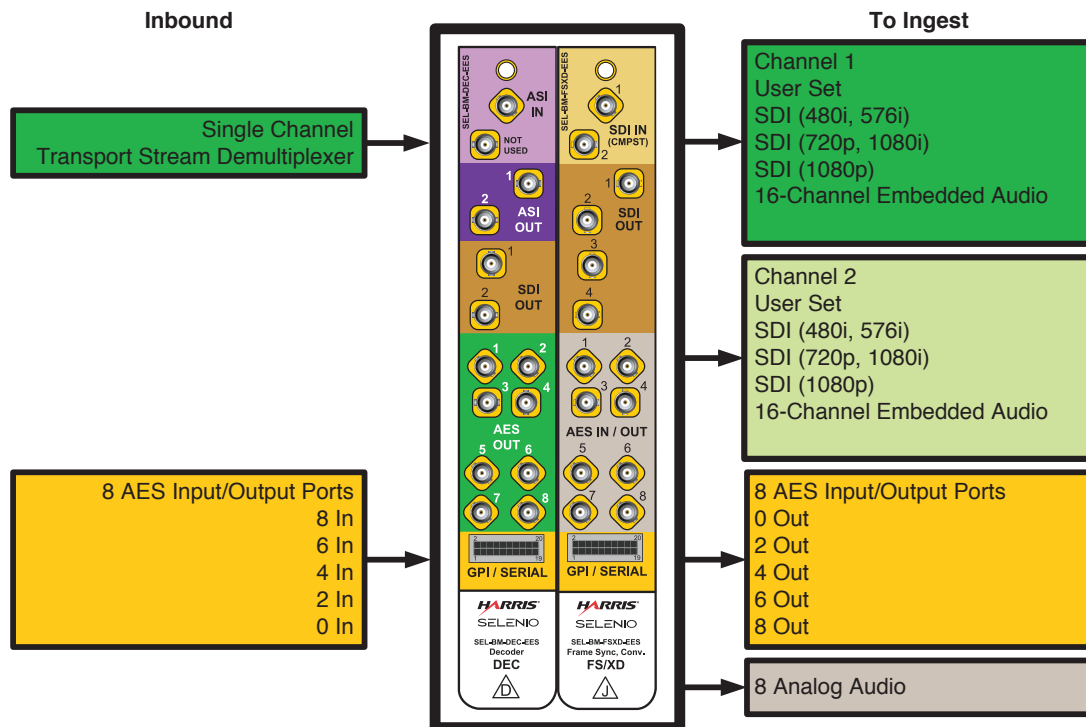

SEL-1DEC1-EES

Multi-standard decoder hardware. Includes single channel of video and four stereo pairs of audio, also includes single back module with HD-BNC connectors for ASI inputs/outputs, SDI video outputs, AES (unbalanced) outputs, GPI inputs/outputs and serial data

SEL-SK-DE-PRO

Software feature key for DEC1 - MPEG-2 4:2:0 and 4:2:2 video profiles, H.264 4:2:0 up to 1080P 3G support

SEL-1XD1-EES

Single-channel video conversion front module with up, down, cross, frame rate and aspect ratio conversion, logo generator/insertor, and full embedded audio processing, includes single back module with HD-BNC connectors for SDI and composite input, SDI outputs, 8 AES (unbalanced) input/output ports and socket/plug for 4 GPI inputs, 4 GPI outputs and two serial data connections

Adding Advanced Audio Options

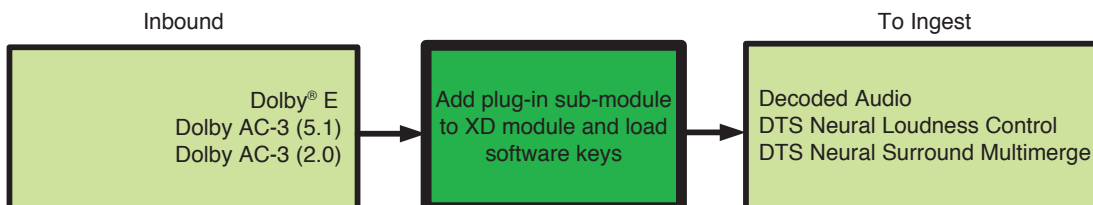

Why Harris?

Harris is uniquely positioned to deliver a solution that simplifies this convergence of traditional baseband infrastructure and the IP/compressed domains. While Selenio is a revolution in terms of what you can do, it's only an evolution in the Harris platforms that the world's leading media providers have depended on for years.

Selenio combines the very best elements of the Harris legacy. A decades-long leadership position in baseband processing. A well-recognized skill-set in compression systems. A world-class networking portfolio. The most-deployed signal processing and compression products in the industry. And the scale to deliver the most advanced technology cost effectively.

Our global reach, financial strength and experience in mission-critical communications systems allow you to deploy Harris technology with confidence. With more than 100 years in broadcasting and nearly 100 technological firsts, Harris is the innovation partner you can count on to be there no matter where you take your business.

For more information, visit:

www.broadcast.harris.com/selenio

Regional Contacts:

North America	+1 800 231 9673
Caribbean and Latin America	+1 786 437 1960
Europe and Africa	+44 118 964 8200
Middle East and South Asia	+971 4 433 8250
Asia, Pacific Rim	+852 2776 0628

Harris is a registered trademark of Harris Corporation. Trademarks and tradenames are the property of their respective companies.



Broadcast Communications Division
9800 South Meridian Boulevard, Suite 300 | Englewood, CO USA 80112 | Tel: +1 303 476 5000
www.broadcast.harris.com